

# MBB400TX12A

Preliminary Specification

Silicon N-channel IGBT

## 1. FEATURES

- \* High speed, low loss IGBT module.
- \* Low driving power:
  - Low input capacitance advanced IGBT.
- \* Low thermal impedance due to direct liquid cooling.
- \* High reliability, high durability module.
- \* Temperature sensor on IGBT.

## 2. ABSOLUTE MAXIMUM RATINGS (T<sub>C</sub>=25°C)

Item	Symbol	Unit	Specification
Collector Emitter Voltage	V <sub>CEs</sub>	V	1200
Gate Emitter Voltage	V <sub>GES</sub>	V	±20
Collector Current	DC	I <sub>C</sub>	400
	1ms	I <sub>CM</sub>	800
Forward Current	DC	I <sub>F</sub>	400
	1ms	I <sub>FM</sub>	800
Maximum Junction Temperature	T <sub>vj max</sub>	°C	175
Temperature under switching conditions	T <sub>vj op</sub>	°C	-40 ~ +150
Storage Temperature	T <sub>stg</sub>	°C	-40 ~ +125
Isolation Voltage	V <sub>ISO</sub>	V <sub>RMS</sub>	2,500 (AC 1 minute)
Screw Torque	Terminals (M6)	-	6.0 (1)
	Mounting (M5)	-	4.0 (2)
	PCB Mounting (M3 Tapping Screw)	-	TBD

Notes: Recommended Value (1)5.5±0.5N·m (2)3.5±0.5N·m

## 3. ELECTRICAL CHARACTERISTICS

Item	Symbol	Unit	Min.	Typ.	Max.	Test Conditions	
Collector Emitter Cut-Off Current	I <sub>CEs</sub>	μA	-	-	200	V <sub>CE</sub> =1200V, V <sub>GE</sub> =0V, T <sub>vj</sub> =25°C	
Gate Emitter Leakage Current	I <sub>GES</sub>	nA	-	-	±500	V <sub>GE</sub> =±20V, V <sub>CE</sub> =0V, T <sub>vj</sub> =25°C	
Collector Emitter Saturation Voltage	V <sub>CEsat</sub>	V	-	1.65	TBD	I <sub>C</sub> =400A, V <sub>GE</sub> =15V, T <sub>vj</sub> =25°C	
			-	1.9	-	I <sub>C</sub> =400A, V <sub>GE</sub> =15V, T <sub>vj</sub> =150°C	
Gate Emitter Threshold Voltage	V <sub>GE(th)</sub>	V	(6.1)	6.8	(7.6)	V <sub>CE</sub> =5V, I <sub>C</sub> =400mA, T <sub>vj</sub> =25°C	
Input Capacitance	C <sub>ies</sub>	nF	-	16	-	V <sub>CE</sub> =10V, V <sub>GE</sub> =0V, f=100kHz, T <sub>vj</sub> =25°C	
Turn On Delay Time	t <sub>d(on)</sub>	μs	-	0.17	TBD	V <sub>CC</sub> =600V, I <sub>C</sub> =400A, L <sub>S</sub> =40nH, R <sub>G</sub> (on/off)=3.3/4.7Ω, V <sub>GE</sub> =+15V/-15V, T <sub>vj</sub> =150°C	
Rise Time	t <sub>r</sub>		-	0.07	TBD		
Turn Off Delay Time	t <sub>d(off)</sub>		-	0.38	TBD		
Fall Time	t <sub>f</sub>		-	0.26	TBD		
Peak Forward Voltage Drop	V <sub>F</sub>	V	-	2.2	TBD	I <sub>F</sub> =400A, V <sub>GE</sub> =0V, T <sub>vj</sub> =25°C	
			-	2.2	-	I <sub>F</sub> =400A, V <sub>GE</sub> =0V, T <sub>vj</sub> =150°C	
Reverse Recovery Time	t <sub>rr</sub>	μs	-	0.36	TBD	V <sub>CC</sub> =600V, I <sub>C</sub> =400A, L <sub>S</sub> =40nH, R <sub>G</sub> (on/off)=3.3/4.7Ω, V <sub>GE</sub> =+15V/-15V, T <sub>vj</sub> =150°C	
Turn On Loss	E <sub>on</sub>	mJ/P	-	32	TBD	Inductive load	
Turn Off Loss	E <sub>off</sub>	mJ/P	-	47	TBD		
Reverse Recovery Loss	E <sub>rr</sub>	mJ/P	-	33	TBD		
Temperature Sensing Diode	Forward Voltage Drop	V <sub>FT</sub>	V	(2.7)	2.85	(3.0)	T <sub>C</sub> =25°C, I <sub>FT</sub> =0.2mA
				(1.85)	2.0	(2.15)	T <sub>C</sub> =150°C, I <sub>FT</sub> =0.2mA
Thermal Resistance	IGBT	R <sub>th(j-w)</sub>	°C/W	-	-	0.128	Junction to water/fin, 10l/min, 50%LLC (per 1 arm)
	FWD	R <sub>th(j-w)</sub>	°C/W	-	-	0.165	

- \* Please contact our representatives at order.
- \* For improvement, specifications are subject to change without notice.
- \* For actual application, please confirm this spec sheet is the newest revision.
- \* ELECTRICAL CHARACTERISTIC items shown in above table are according to IEC 60747-2 and IEC 60747-9.
- \* Switching loss depends on L<sub>s</sub>, gate driver, C<sub>ge</sub>, V<sub>ge</sub>, etc.
- Please optimize those values so that switching surge voltage does not exceed the rating voltage.

# MBB400TX12A

Preliminary Specification

## 4. PACKAGE OUTLINE DRAWING

**TENTATIVE**

Unit in mm

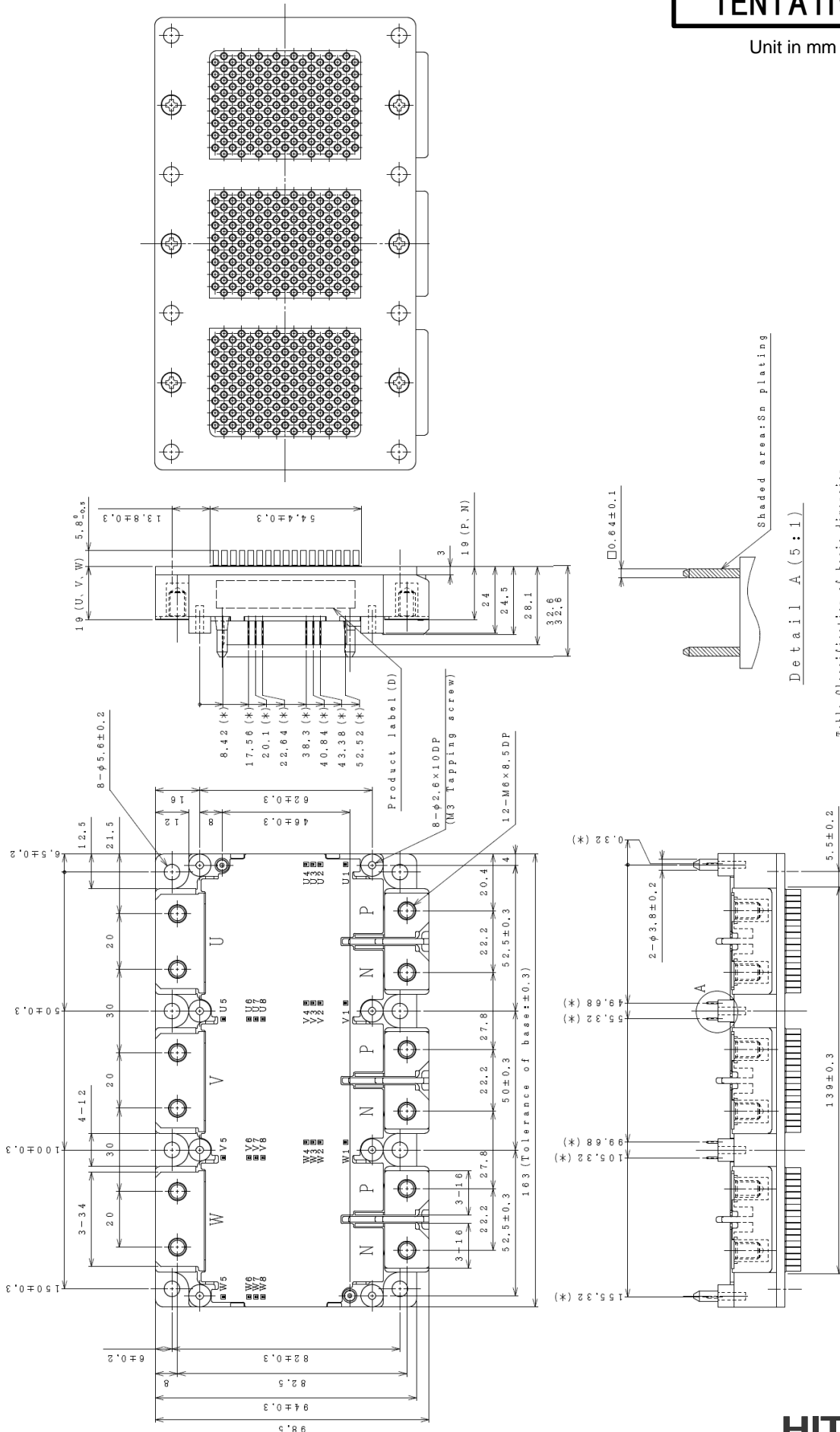

Table Classification of basic dimension

Classification of basic dimension (x) (unit:mm)	Tolerance
0.5 ≤ (x) ≤ 3	±0.2
3 < (x) ≤ 6	±0.3
6 < (x) ≤ 30	±0.5
30 < (x) ≤ 120	±0.8
120 < (x) ≤ 400	±1.2

(Note 1) Dimension of (\*) is that of the root portion of terminal. (Tolerance:±0.5)  
 (Note 2) Dimensional tolerance follows the right table, if not described.

# MBB400TX12A

Preliminary Specification

## 5. CIRCUIT DIAGRAM

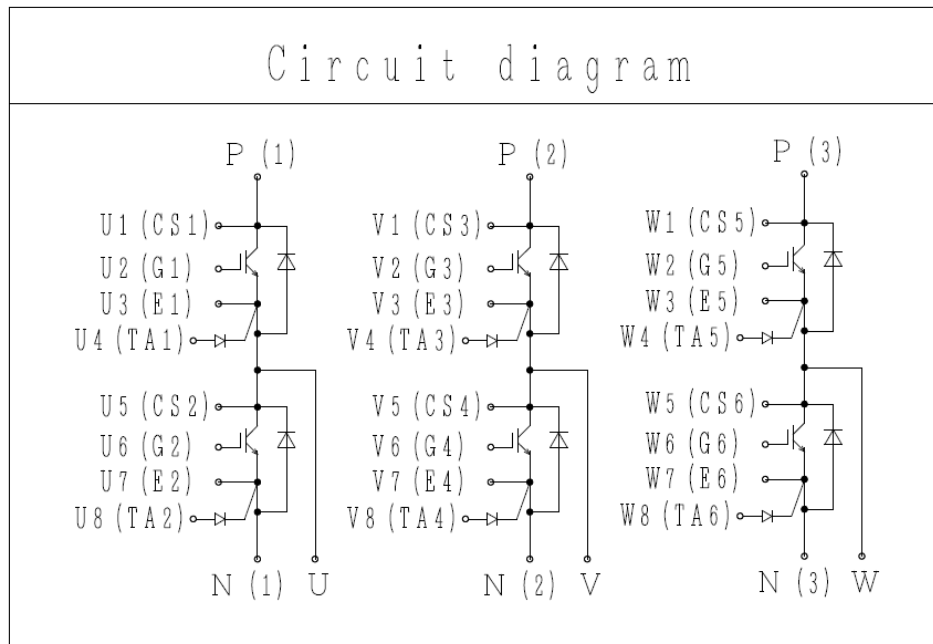

# MBB400TX12A

Preliminary Specification

## 6. STATIC CHARACTERISTICS

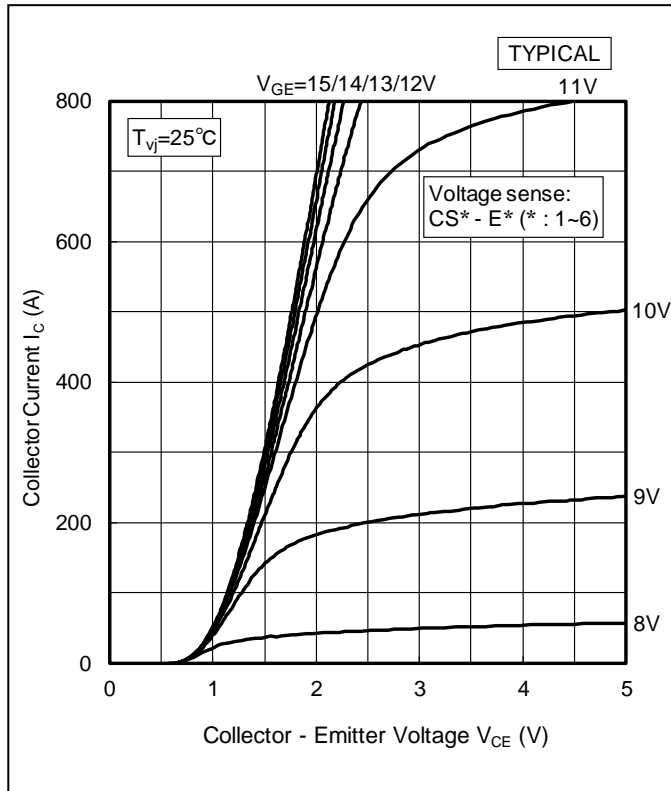

Collector Current vs. Collector - Emitter Voltage

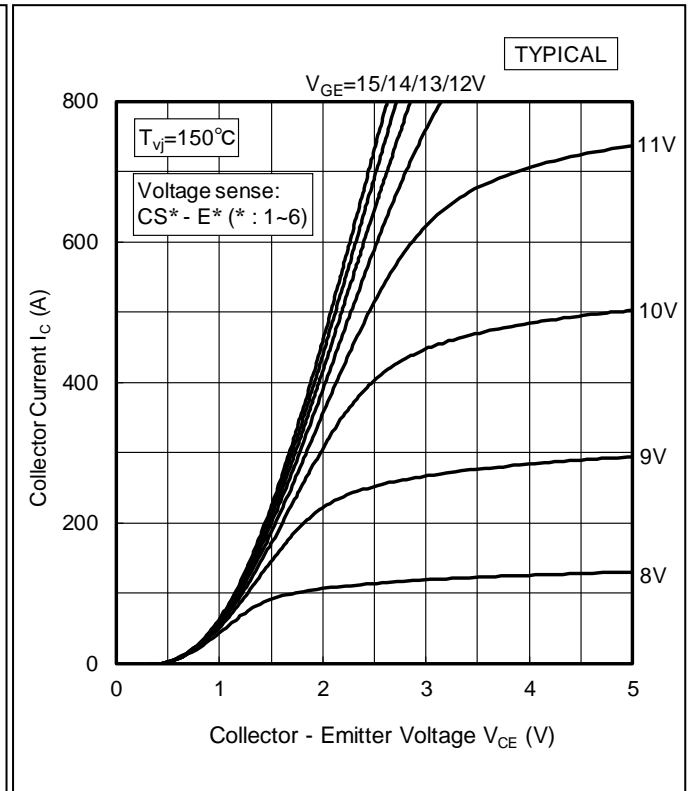

Collector Current vs. Collector - Emitter Voltage

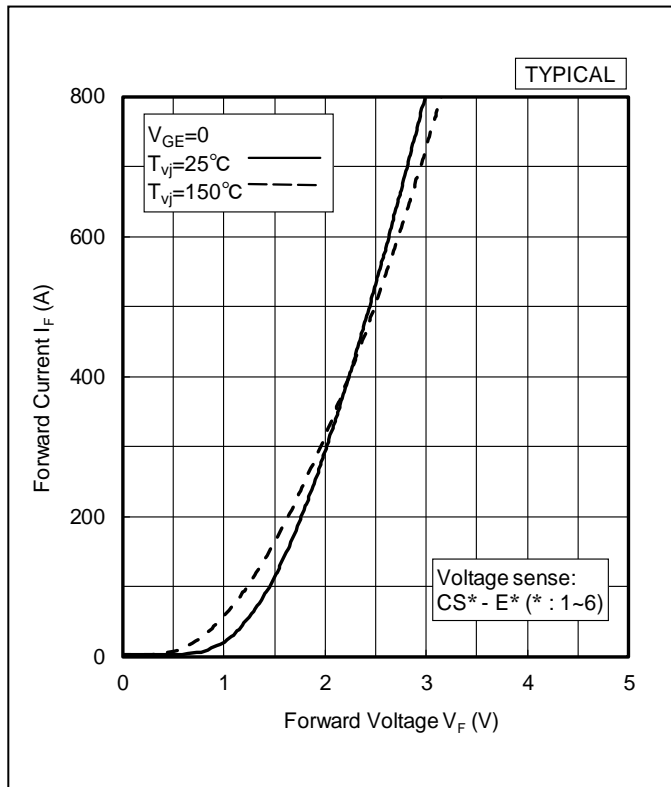

Forward Voltage of Free-Wheeling Diode

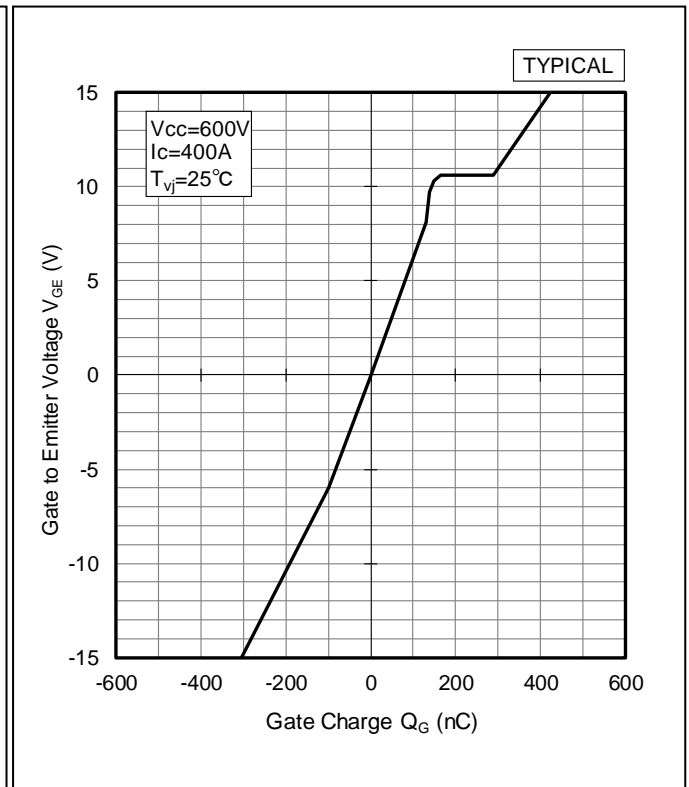

Gate to Emitter Voltage vs. Gate Charge

# MBB400TX12A

## Preliminary Specification

### 7. DYNAMIC CHARACTERISTICS

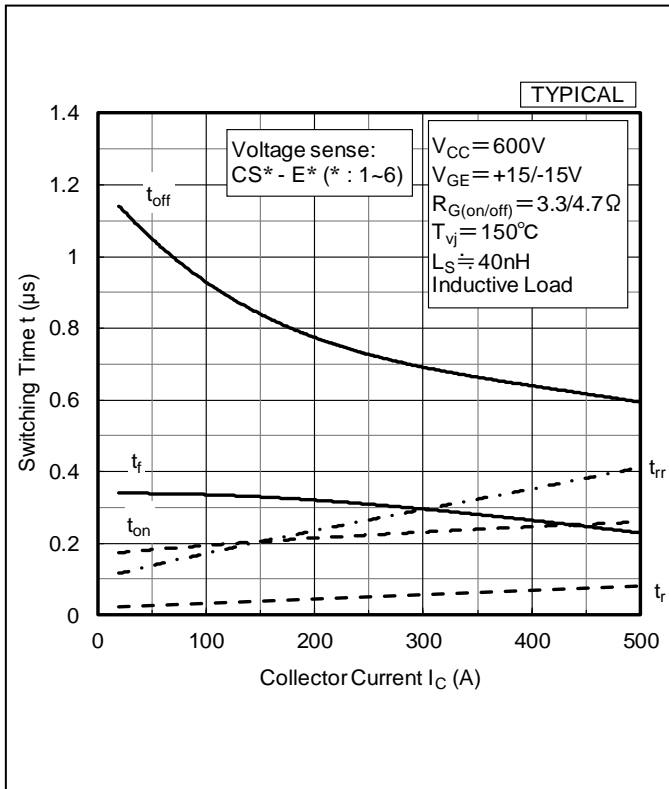

Switching Time vs. Collector Current

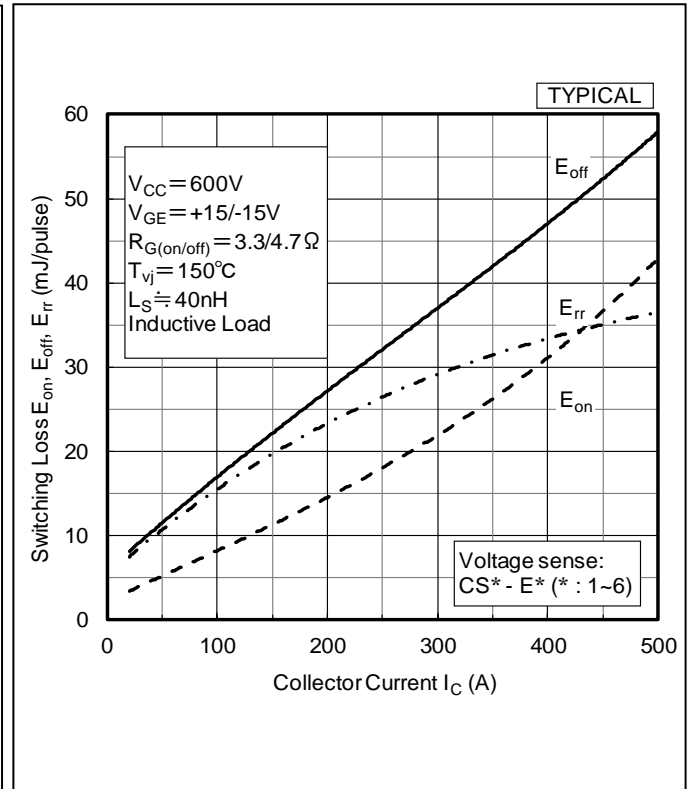

Switching Loss vs. Collector Current

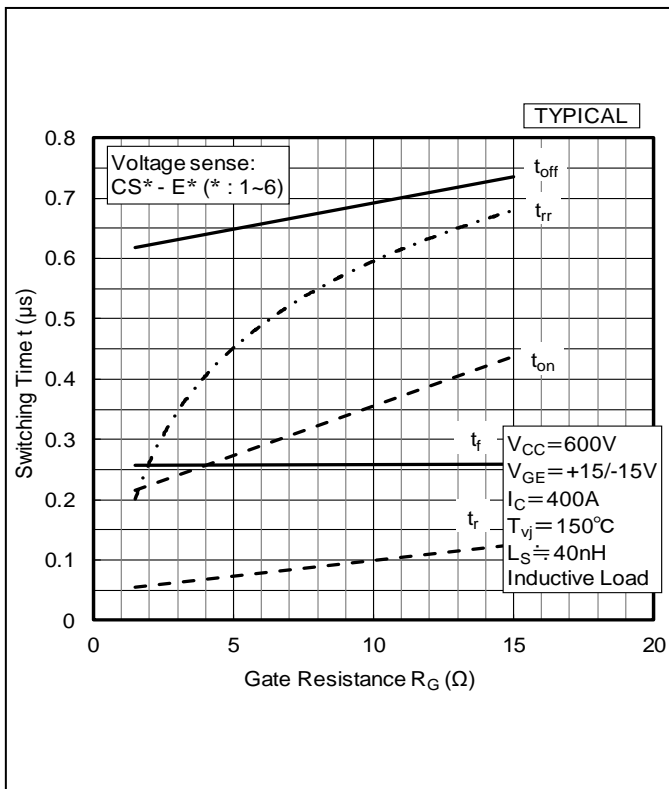

Switching Time vs. Gate Resistance

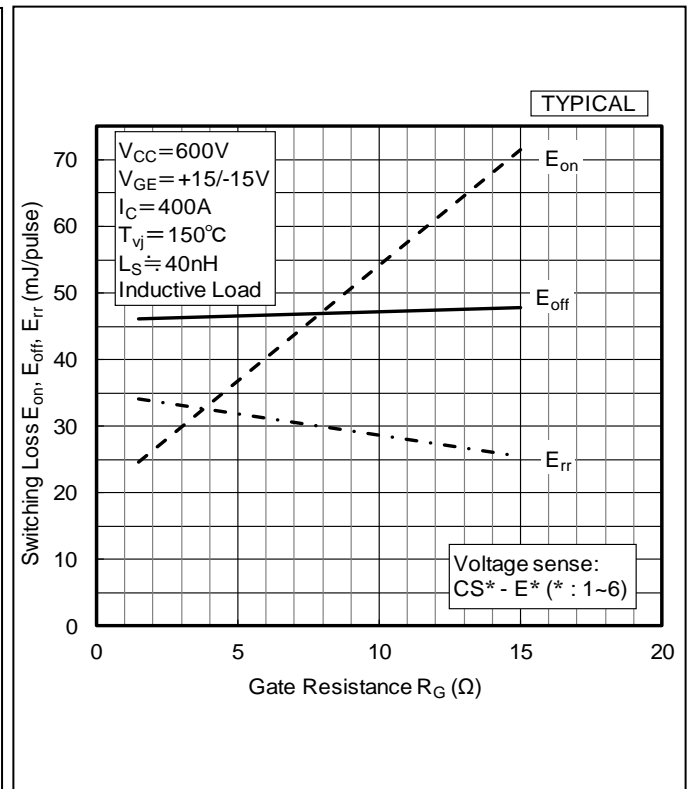

Switching Loss vs. Gate Resistance

# MBB400TX12A

Preliminary Specification

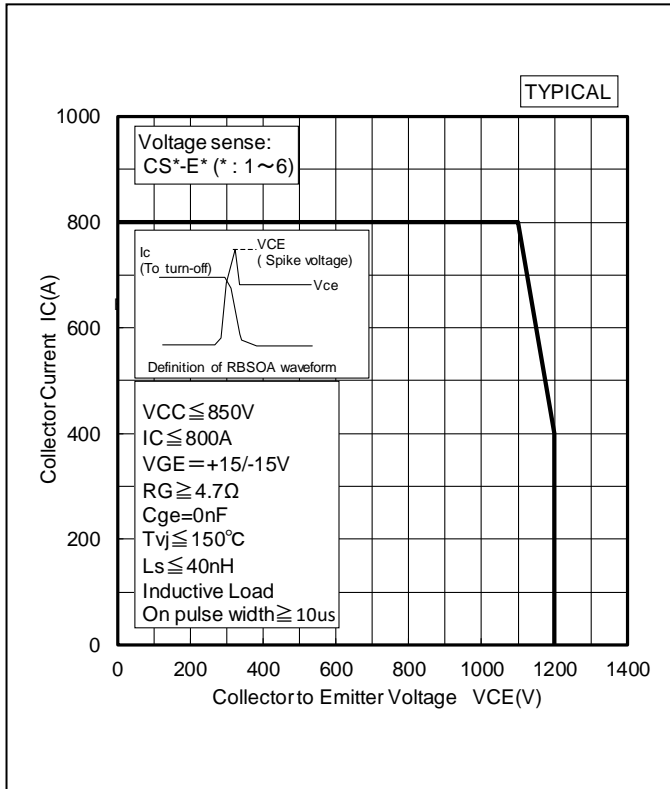

Reverse Biased Safety Operating Area

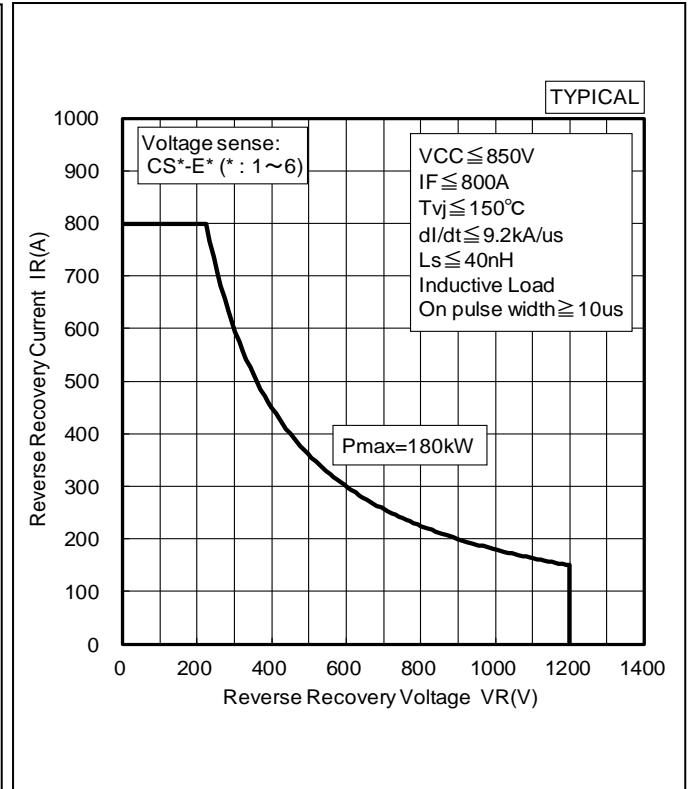

Reverse Recovery Safety Operating Area

## 8. THERMAL CHARACTERISTICS

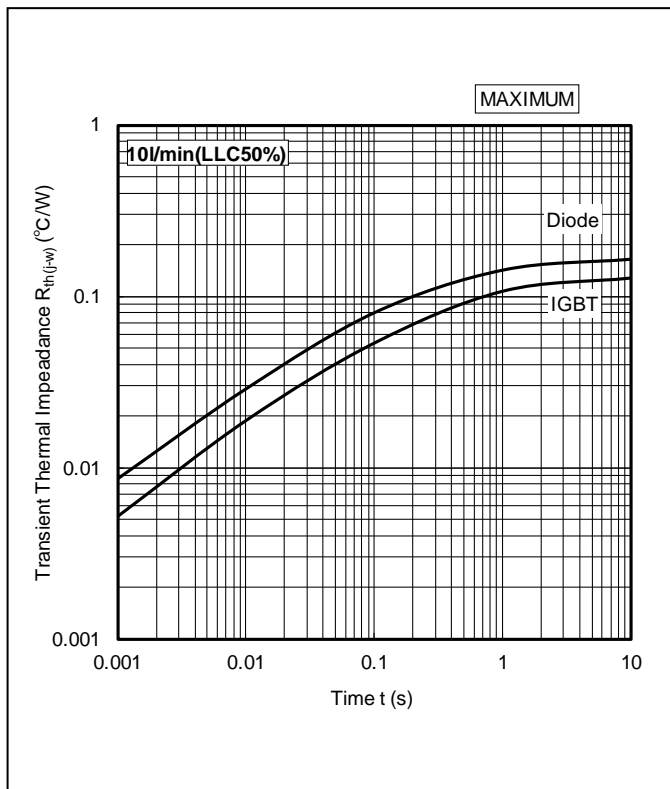

Transient Thermal Impedance Characteristics

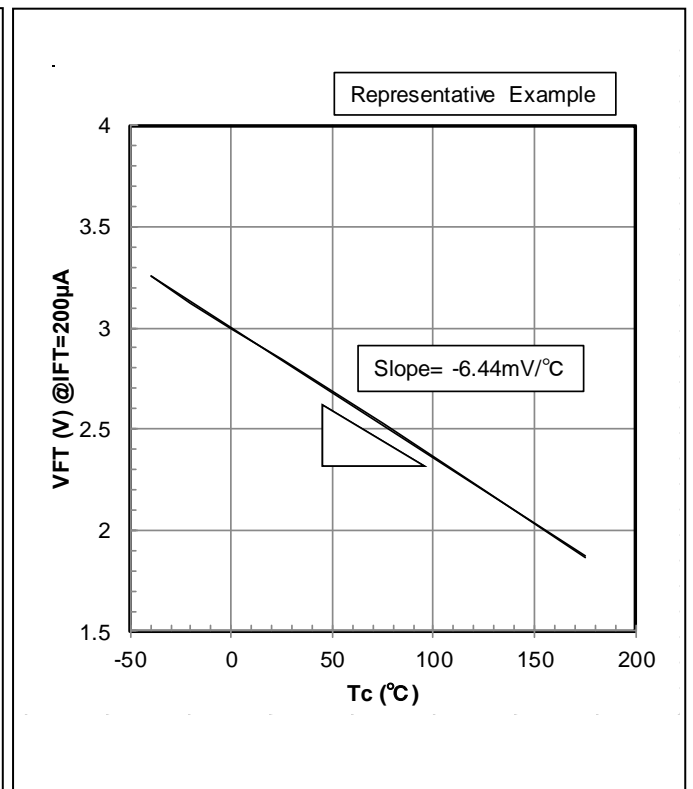

On-chip Temperature Sensing Diode Characteristic

# MBB400TX12A

Preliminary Specification

## 9. PRECAUTIONS

### 9-1. Storage and Shipping Precautions

#### Important Notices

- (1) IGBT modules should always be stored under the following conditions.
  - Temperature : 40 degrees Celsius, maximum.
  - Humidity : 60% Relative Humidity, maximum.
  - Dust : Avoid storing the module in locations subject to dust.
  - Harmful substances : The installation location should be free of corrosive gases such as sulfur dioxide and chlorine gas.
  - Other : Do not remove the conductive sponges mounted between terminals of gate, emitter, collector, temperature sensing anode.
- (2) Shipping Method
  - To prevent the case cracking and/or the electrode bending, appropriate consideration should be given to properly insulate the shipping container from mechanical shock or severe vibration situation.
  - Do not throw or drop the case while shipping. Treat them with care. The devices may break if they are not handled with care. Please do not use the IGBT modules that were dropped or damaged.
  - Appropriate labeling on the outside of the shipping container should always be present.
  - The shipping container itself should always be properly protected from both rain and water.

### 9-2. Precautions against Electrostatic Failure

#### Important Notices

Because the IGBT has a MOS gate structure and temperature sensing diode, you should always take the following precautions as measures to avoid generating static electricity.

- Before starting operation, do not remove the conductive sponge mounted between terminals of gate, emitter, collector, temperature sensing anode.
- When handling the IGBT module, ground our body via a high-value resistor (between 100k $\Omega$  and 1M $\Omega$ ), hold the package body, and do not touch the terminals of gate, temperature sensing anode and cathode.
- Be sure to ground any parts which the IGBT module may touch, such as the work table or soldering iron.
- Before testing or inspection, be sure to check that any residual electric charge in measuring instruments has been removed. Apply voltage to each terminal starting at 0V and return to 0V when finishing.

# MBB400TX12A

Preliminary Specification

## HITACHI POWER SEMICONDUCTORS

### Notices

1. The information given herein, including the specifications and dimensions, is subject to change without prior notice to improve product characteristics. Before ordering, purchasers are advised to contact Hitachi sales department for the latest version of this data sheets.
2. Please be sure to read "Precautions for Safe Use and Notices" in the individual brochure before use.
3. In cases where extremely high reliability is required (such as use in nuclear power control, aerospace and aviation, traffic equipment, life-support-related medical equipment, fuel control equipment and various kinds of safety equipment), safety should be ensured by using semiconductor devices that feature assured safety or by means of users' fail-safe precautions or other arrangement. Or consult Hitachi's sales department staff.
4. In no event shall Hitachi be liable for any damages that may result from an accident or any other cause during operation of the user's units according to this data sheets. Hitachi assumes no responsibility for any intellectual property claims or any other problems that may result from applications of information, products or circuits described in this data sheets.
5. In no event shall Hitachi be liable for any failure in a semiconductor device or any secondary damage resulting from use at a value exceeding the absolute maximum rating.
6. No license is granted by this data sheets under any patents or other rights of any third party or Hitachi Power Semiconductor Device, Ltd.
7. This data sheets may not be reproduced or duplicated, in any form, in whole or in part, without the expressed written permission of Hitachi Power Semiconductor Device, Ltd.
8. The products (technologies) described in this data sheets are not to be provided to any party whose purpose in their application will hinder maintenance of international peace and safety not are they to be applied to that purpose by their direct purchasers or any third party. When exporting these products (technologies), the necessary procedures are to be taken in accordance with related laws and regulations.

- For inquiries relating to the products, please contact nearest overseas representatives that is located "Inquiry" portion on the top page of a home page.

Hitachi power semiconductor home page address <http://www.hitachi-power-semiconductor-device.co.jp/en/>