

## CURRENT SENSOR

---

PRODUCT SERIES: STB-LA  
STB-50LA  
PRODUCT PART NUMBER: STB-100LA , STB-150LA  
STB-50LA/N  
STB-100LA/N , STB-150LA/N  
VERSION: Ver 3.6

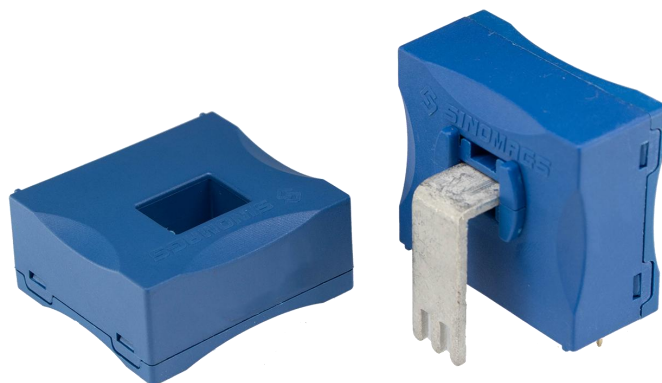

Sinomags Technology Co., Ltd.

## CONTENT

1.	Description .....	2
2.	STB-50LA & STB-50LA/N Electrical parameters .....	3
3.	STB-100LA & STB-100LA/N Electrical parameters .....	4
4.	STB-150LA & STB-150LA/N Electrical parameters .....	5
5.	Sampling resistance Specification table .....	6
6.	STB-50LA & STB-100LA & STB-150LA Dimensions & Pin define .....	7
7.	STB-50LA/N & STB-100LA/N & STB-150LA/N Dimensions & Pin define .....	8

## 1. Description

STB-LA/Z series current sensors are based on close loop principle with TMR technology. The sensor can detect the current with DC, AC, pulse and irregular wave shape.

### Typical application

- Solar inverter
- Direct-current dynamo
- Switched model power supplies (SMPS)
- BMS
- Solar inverter

### General parameters

Parameter	Symbol	Unit	Value
Working temperature	T_A	°C	-40 ~ 85
Storage temperature	T_stg	°C	-40 ~ 95
Secondary Coil Res.@25°C	Rs	Ω	65 ± 2
Secondary Coil Res.@85°C	Rs	Ω	85 ± 2
Mass STB-xxxLA	m	g	40
Mass STB-xxxLA/N	m	g	28

### Maximum effective value

Parameter	Symbol	Unit	Value
Supply voltage (non demolition)	V <sub>C</sub>	V	± 16
ESD Class (HBM)	U <sub>ESD</sub>	kV	4

Remark: the unrecoverable damage may occur when the product works on the conditions over the absolute maximum ratings. Long-time working on the absolute maximum ratings may cause the degradation on performance and reliability.

### Isolation parameters

Parameter	Symbol	Unit	Value	Remark
RMS voltage for AC test 50Hz/1 min	U <sub>d</sub>	kV	5	
Impulse withstand voltage 1.2/50μs	Ū <sub>w</sub>	kV	10	
Clearance distance (pri. -sec)	d <sub>Cl</sub>	mm	13	Shortest distance through air
Creepage distance (pri. -sec)	d <sub>Cp</sub>	mm	13	Shortest path along device body
Case material			V0 according to UL 94	

## 2. STB-50LA & STB-50LA/N Electrical parameters

Condition:  $V_{cc} = 5.0\text{ V}$ ,  $R_L = 10\text{ k}\Omega$ ,  $T_A = 25^\circ\text{C}$ , unless specified.

Parameters	Symbol	Unit	Min.	Typ.	Max.	Remark
Primary nominal rms current	$I_{pn}$	A		50		
Primary current measuring range	$I_{pm}$	A	-200		200	Remark1
Supply voltage	$V_{cc}$	V	$\pm 12$		$\pm 15$	
Secondary Coil turns	$N_s$	N		2000		
Sampling resistance SPEC	$R_m$	$\Omega$		33		
Secondary Coil Rated output current	$I_{sn}$	mA		25		
Consumption current	$I_{cc}$	mA		$10 + I_s$		$I_s = \text{ABS}(I_p / N_s)$
Sensitivity error	X	%			$\pm 0.5$	within $I_{pn}$
Linearity error within $I_{pn}$	$\xi_L$	% of $I_{pn}$			$\pm 0.10$	
offset	$I_{OE}$	mA			$\pm 0.10$	@ $I_p = 0\text{ A}$
Magnetic bias current	$I_{OM}$	mA			$\pm 0.25$	$3 * I_{pn}$ remanence
Offset Temperature drift	$I_{OT}$	mA		$\pm 0.15$	$\pm 0.30$	$-40^\circ\text{C} \sim 85^\circ\text{C}$
Reaction tim	$t_{ra}$	$\mu\text{s}$			0.3	@10% of $I_{pn}$
Step response tim (Remark2)	$t_{res}$	$\mu\text{s}$			0.5	@90% of $I_{pn}$
-1dB band width	BW	kHz		150		

Remark:

- 1) The maximum test current is 200 A, DC or peak current,  $85^\circ\text{C}$ ,  $V_{cc} = \pm 12\text{ V}$  (tolerance  $\pm 0.3\text{ V}$ ), sampling resistor  $R_M \leq 33\ \Omega$ .  $X \leq 1\%$ . If a larger maximum detection current is required, refer to the sampling resistance specification sheet.
- 2)  $di/dt = 100\text{ A} / \mu\text{s}$ .

### 3. STB-100LA & STB-100LA/N Electrical parameters

Condition:  $V_{cc} = 5.0\text{ V}$ ,  $R_L = 10\text{ k}\Omega$ ,  $T_A = 25^\circ\text{C}$ , unless specified.

Parameters	Symbol	Unit	Min.	Typ.	Max.	Remark
Primary nominal rms current	$I_{pn}$	A		100		
Primary current measuring range	$I_{pm}$	A	-200		200	Remark1
Supply voltage	$V_{cc}$	V	$\pm 12$		$\pm 15$	
Secondary Coil turns	$N_s$	N		2000		
Sampling resistance SPEC	$R_m$	$\Omega$		33		
Secondary Coil Rated output current	$I_{sn}$	mA		50		
Consumption current	$I_{cc}$	mA		$10 + I_s$		$I_s = \text{ABS}(I_p / N_s)$
Sensitivity error	X	%			$\pm 0.5$	within $I_{pn}$
Linearity error within $I_{pn}$	$\xi_L$	% of $I_{pn}$			$\pm 0.10$	
offset	$I_{OE}$	mA			$\pm 0.10$	@ $I_p = 0\text{ A}$
Magnetic bias current	$I_{OM}$	mA			$\pm 0.25$	$3 * I_{pn}$ remanence
Offset Temperature drift	$I_{OT}$	mA		$\pm 0.15$	$\pm 0.30$	$-40^\circ\text{C} \sim 85^\circ\text{C}$
Reaction tim	$t_{ra}$	$\mu\text{s}$			0.3	@10% of $I_{pn}$
Step response tim (Remark2)	$t_{res}$	$\mu\text{s}$			0.5	@90% of $I_{pn}$
-1dB band width	BW	kHz		150		

Remark:

- 3) The maximum test current is 200 A, DC or peak current,  $85^\circ\text{C}$ ,  $V_{cc} = \pm 12\text{ V}$  (tolerance  $\pm 0.3\text{ V}$ ), sampling resistor  $R_M \leq 33\ \Omega$ .  $X \leq 1\%$ . If a larger maximum detection current is required, refer to the sampling resistance specification sheet.
- 4)  $di/dt = 100\text{ A} / \mu\text{s}$ .

#### 4. STB-150LA & STB-150LA/N Electrical parameters

Condition:  $V_{cc} = 5.0\text{ V}$ ,  $R_L = 10\text{ k}\Omega$ ,  $T_A = 25^\circ\text{C}$ , unless specified.

Parameters	Symbol	Unit	Min.	Typ.	Max.	Remark
Primary nominal rms current	$I_{pn}$	A		150		
Primary current measuring range	$I_{pm}$	A	-240		240	(Remark3)
Supply voltage	$V_{cc}$	V	$\pm 12$		$\pm 15$	
Secondary Coil turns	$N_s$	N		2000		
Sampling resistance SPEC	$R_m$	$\Omega$		16.5		
Secondary Coil Rated output current	$I_{sn}$	mA		75		
Consumption current	$I_{cc}$	mA		$10 + I_s$		$I_s = \text{ABS}(I_p / N_s)$
Sensitivity error	X	%			$\pm 0.5$	within $I_{pn}$
Linearity error within $I_{pn}$	$\xi_L$	% of $I_{pn}$			$\pm 0.10$	within $I_{pn}$
offset	$I_{OE}$	mA			$\pm 0.10$	@ $I_p = 0\text{ A}$
Magnetic bias current	$I_{OM}$	mA			$\pm 0.25$	$3 * I_{pn}$ remanence
offset Temperature drift	$I_{OT}$	mA		$\pm 0.15$	$\pm 0.30$	$-40^\circ\text{C} \sim 85^\circ\text{C}$
Reaction time	$t_{ra}$	$\mu\text{s}$			0.3	@10% of $I_{pn}$
Step response (Remark4)	$t_{res}$	$\mu\text{s}$			0.5	@90% of $I_{pn}$
-1dB band width	BW	kHz		150		

Remark:

- 5) The maximum test current is 300 A, Short-circuit protection, Duration  $\leq 400\ \mu\text{s}$ , @  $di/dt > 1\text{ A}/\mu\text{s}$ ,  $80^\circ\text{C}$ ,  $V_{cc} = \pm 12\text{ V}$  (tolerance  $\pm 0.3\text{ V}$ ), Sampling resistance  $R_M \leq 16.4\ \Omega$ ,  $X \leq 5\%$ .
- 6)  $di/dt = 100\text{ A}/\mu\text{s}$ .

## 5. Sampling resistance Specification table

Support Voltage	12 V	15 V	Recommend sampling resistance ( $\Omega$ )
Peak Current (A)	Max Value ( $\Omega$ )	Max Value ( $\Omega$ )	
50	309.0	429.0	33
60	245.0	345.0	
70	199.3	285.0	
80	165.0	240.0	
90	138.3	205.0	
100	117.0	177.0	
110	99.5	154.1	16.4
120	85.0	135.0	
130	72.7	118.8	
140	62.1	105.0	
150	53.0	93.0	
160	45.0	82.5	
170	37.9	73.2	
180	31.7	65.0	
190	26.1	57.6	
200	21.0	51.0	
210	16.4	45.0	5
220	12.3	39.5	
230	8.5	34.6	
240	5.0	30.0	
250		25.8	
260		21.9	
270		18.3	
280		15.0	
290		11.9	
300		9.0	
Temperature range: $-40^{\circ}\text{C} \sim 85^{\circ}\text{C}$			

Remark:

- 1) Working on current exceeding 150 A of long time .It may cause the heat output of the sensor to exceed the designed normal working state ;
- 2) When Primary current more than 240 A (peak current). It may lead to the decrease of sensor output accuracy;

## 6. STB-50LA & STB-100LA & STB-150LA Dimensions & Pin define

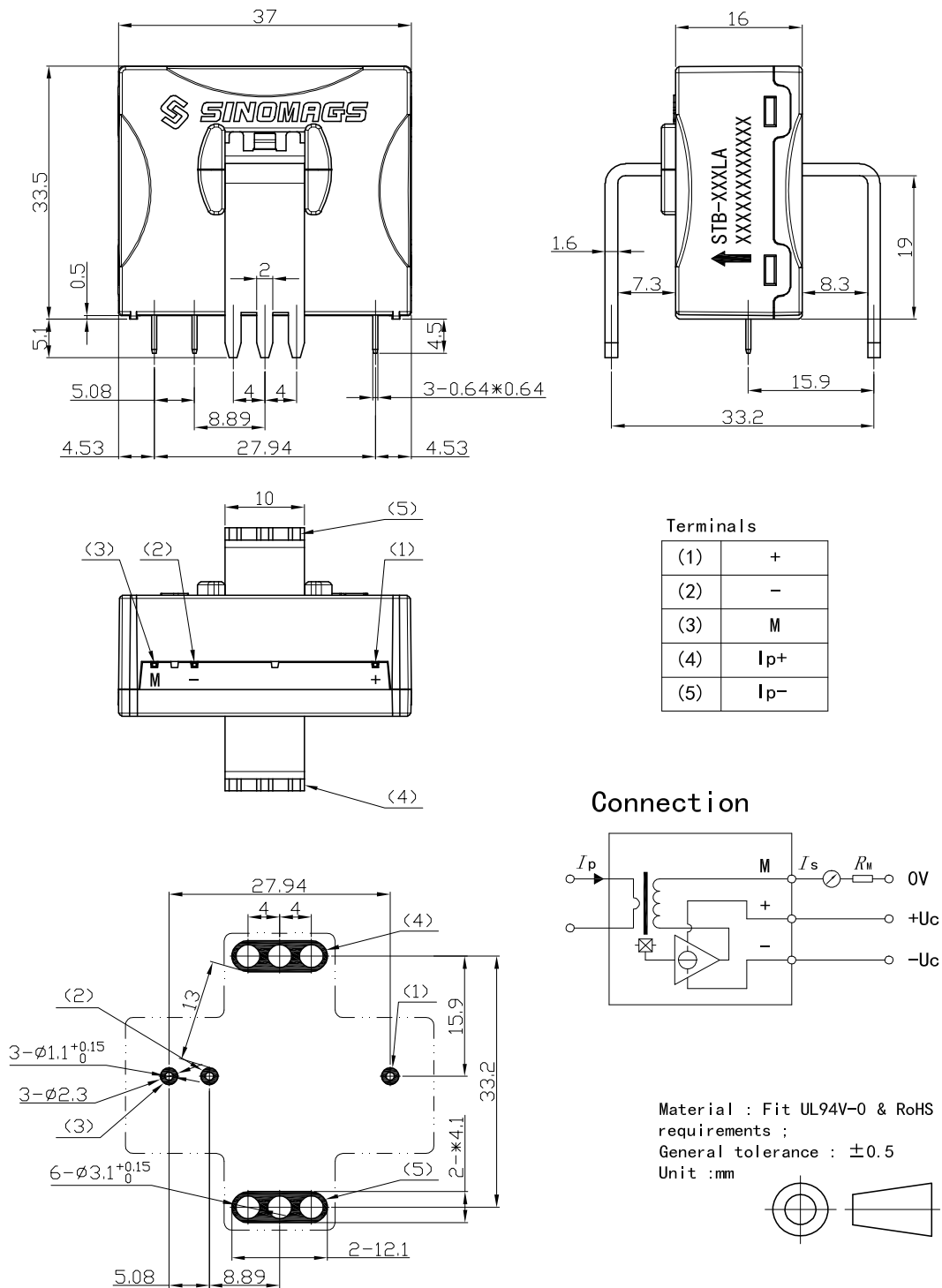

### Mechanical properties

- General tolerances ±0.5 mm;
- Fixed connection primary coil 6 PIN size is 2 \* 1.6mm , The recommended diameter of PCB pad is 1.1 mm;
- Fixed connection second coil 3 PIN size is 0.6 \* 0.6mm, he recommended diameter of PCB pad is 1.1 mm;



## 7. STB-50LA/N & STB-100LA/N & STB-150LA/N Dimensions & Pin

define

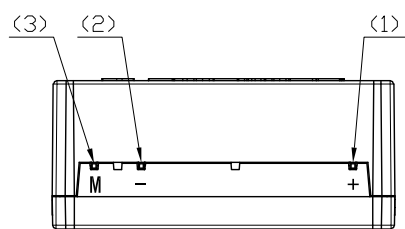
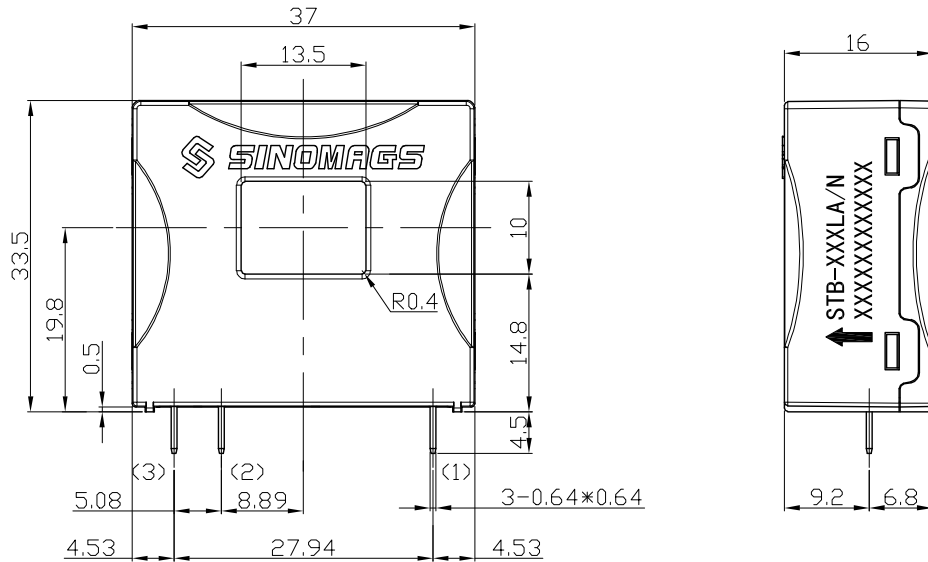

Terminals

(1)	+
(2)	-
(3)	M

Connection

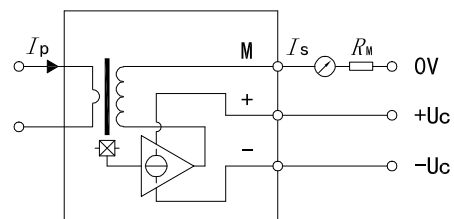

Material : Fit UL94V-0 & RoHS requirements ;  
 General tolerance :  $\pm 0.5$   
 Unit : mm

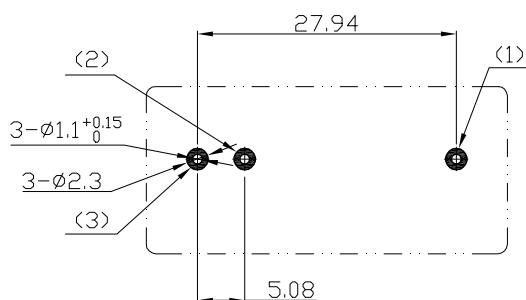
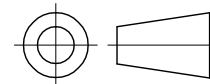

### Mechanical properties

- General tolerances  $\pm 0.5$  mm;
- Fixed connection second coil 3 PIN size is 0.6 \* 0.6mm . The recommended diameter of PCB pad is 1.1 mm;